

SINGLE DOOR INSTALLATION		
STRIKE	DIMENSION "B"	MIN. STILE
299	2 1/2"	4 3/8"
264	2 1/4"	4 1/8"
1606	2 1/16"	3 15/16"

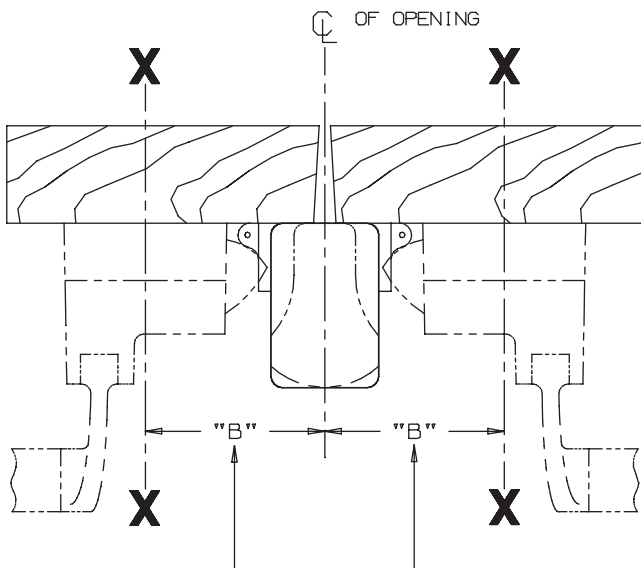

DOUBLE DOOR INSTALLATION WITH VON DUPRIN MULLIONS			
MULLION	STRIKE	DIMENSION "B"	MIN. STILE
5654	299	3 1/16"	4 1/4"
5654	264	2 13/16"	4"
4954	299	3 1/2"	4 11/16"
4954	264	3 1/4"	4 7/16"
1654	1606	3 1/16"	4 1/4"

FOR OUTSIDE TRIM PREPARATION, WHEN REQUIRED, SEE ADDITIONAL TRIM TEMPLATE.

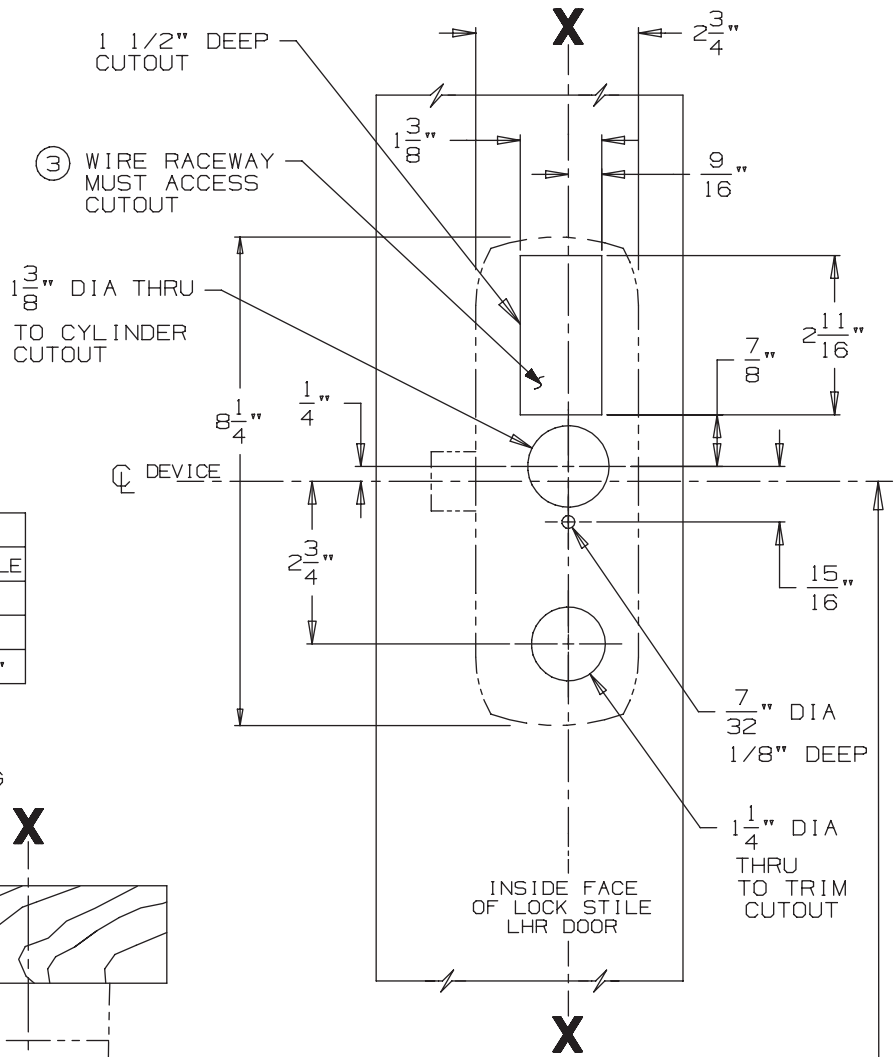

SINGLE DOOR OPENING
39 13/16" TO FINISHED FLOOR

DOUBLE DOOR OPENING
WITH VON DUPRIN MULLION
39 11/16" TO FINISHED FLOOR

CROSSBAR 36 13/16" FROM FINISHED FLOOR

LHR SHOWN
RHR OPPOSITE

NOTES:

1. MOUNTING HOLES TO BE PREPARED AT INSTALLATION ON DOOR.
2. WIRING GOES THROUGH DOOR AND NOT DEVICE.

E88TP Series Rim Device
(Wood Door)

VON DUPRIN®

NOTES: SEE MASTER SHEET #10001 FOR SUGGESTED REINFORCING

TEMPLATE NUMBER:

W10183_a

DATE:
05-29-13