



INSTALLATION INSTRUCTIONS

For Full Height Top Mount Waste Containers
With Rev-A-Motion

For face frame style cabinets see steps 1A-4A
For frameless style cabinets see steps 1B-5B
For cabinets with inset doors see steps 1C-4C

Face Frame Cabinet Installation

Step 1A Preparing the Unit for installation

Remove the Gas Spring from the unit.

This is done by removing the two retainer clips from each of the ball sockets and then popping the spring ends from the ball studs. (SEE FIGURE 1A)

Disengage the cabinet members from the unit by pressing the release levers on the 2 slides and pulling them away from the product members. (SEE FIGURE 1A)

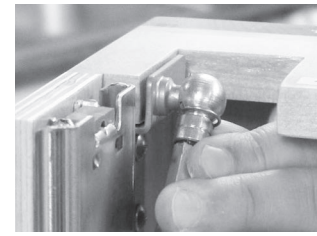

FIGURE 1A



Step 2A Attaching Rear Mounting Strap

Fasten the rear strap assembly to the rear cabinet wall using the (4) #8 x 5/8" pan head screws provided. The CENTER slot of each rear socket should be positioned 17-15/16" (for 50 qt. frames) or 12-7/8" (for 35 qt. frames) from the floor of the cabinet as shown in FIGURE 2A. It is best to start with two screws in the center slots in case adjustments are necessary. Make sure to center the strap assembly left to right according to the opening of the face frame. (SEE FIG 2A)

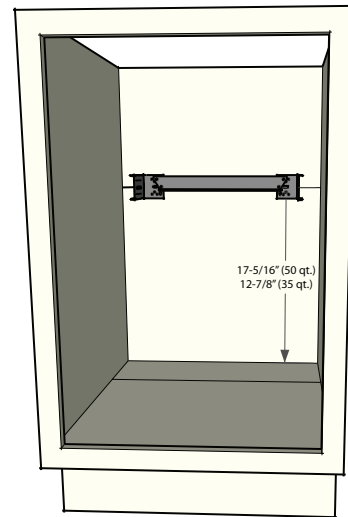

FIGURE 2A

Note: If rear of cabinet is thinner than 1/2", a furring strip should be used between the back wall and the mounting strap to ensure the rear mounting strap is properly attached. Keep in mind the minimum depth required is 21-3/4" and is measured from the back of the door.

Step 3A Assembling Side Mounting Brackets

For face frame applications, only the product member bracket and the side mounting bracket are necessary. (SEE FIGURE 3A)

Please refer to Table A for the proper hole alignment. If the table does not apply to the cabinet in use, the outer slots will provide a fully adjustable option to fit virtually any opening. Fasten the brackets according to table A using the M5 nuts, bolts, and washers provided.

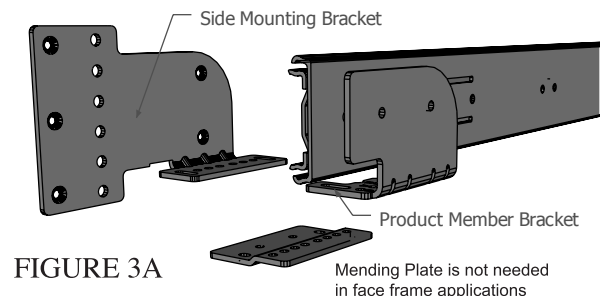

FIGURE 3A

TABLE A	SIDE MOUNTING BRACKET HOLE LOCATION	PRODUCT MEMBER HOLE LOCATION	MENDING PLATE HOLE LOCATION
1.5" Face Frame	C	C	N/A
1.625" Face Frame	B	B	N/A
1.75" Face Frame	A	A	N/A

Step 4A Attaching Slides to Cabinet

While supporting the front of the side mounting bracket engage the back of the slide with the rear strap assembly by sliding it into the outer socket of the assembly. The product member should be pushed into the rear strap assembly until the front of each product member and each side-mounting bracket is flush with the front of the face frame. This is a press fit and there will be resistance. (SEE FIGURE 4A)

Continue to support the front of the slide. Do not let it fall as it may damage the rear strap assembly.

Locate the bottom of the side-mounting bracket 15 3/4" (for 50 qt. frames) or 10-11/16" (for 35 qt. frames) from the floor of the cabinet. Attach each bracket to the inside of the face frame using the (3) #6 x 5/8" flat head screws provided. (SEE FIGURE 5A)

Note: it is recommended to pre-drill using a 3/32" drill bit

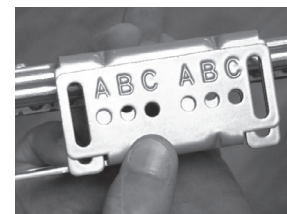

1-1/2" Face Frame Example

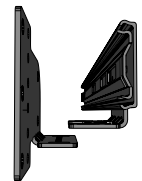

-Product Member Top
-Side Mount Brkt Bottom

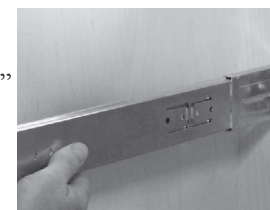

FIGURE 4A

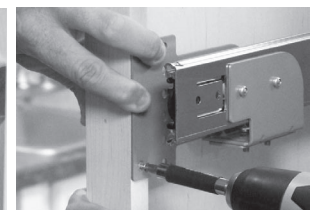

FIGURE 5A

PROCEED TO STEP 6

Frameless Cabinet Installation

Step 1B Installing Side Mounting Brackets

Locate the bottom of the side mounting bracket 15-3/4" (for 50 qt. frames) or 10-11/16" (for 35 qt. frames) from the floor. The brackets also need to be flush with the front of the cabinet wall. Move the bracket up or down to the nearest set of system holes. Use the (3) M6.3 flat head euro screws for each side-mounting bracket with the corresponding 32mm system hole. You may also use (2) #6 X 5/8" screws at the rear of the bracket for added stability. Measure the distance that the bracket needed to move up or down to engage the system holes. If the bracket needed to move up, add the measured dimension to 17-15/16" (for 50 qt. frames) or 12-7/8" (for 35 qt. frames). If the bracket needed to move down subtract the dimension from 17-15/16" or 12-7/8". (USE THIS DIMENSION IN THE NEXT STEP)

STEP 2B Attaching Rear Mounting Strap

Position the rear strap assembly centered on the back wall and elevated so that the center slot of each rear socket is positioned at the newly formulated dimension. (For Example: For a 50 qt. frame - If the bracket needed to move up 1/16", the center slot should be located at 18" from the floor). If the side mount bracket did not need to move up or down from the 15-3/4" simply use 17-15/16" as the center slot dimension on the rear strap assembly. (SEE FIGURE 2B)

Fasten the rear strap assembly to the rear cabinet wall using the (4) #8 x 5/8" pan head screws provided. Make sure to center the strap assembly left to right according to the opening of the cabinet. It is best to start with 2 screws in the center slots in case adjustments are necessary.

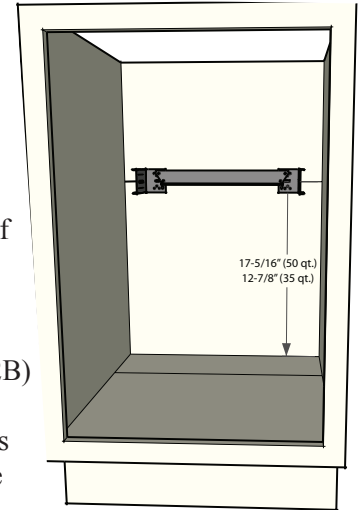

FIGURE 2B

Note: If rear of cabinet is thinner than 1/2", a furring strip should be used between the back wall and the mounting strap to ensure the rear mounting strap is properly attached. Keep in mind the minimum depth required is 21-3/4" and is measured from the back of the door.

Step 3B Assembling Mending Plate to Side Mounting Brackets

For frameless cabinet applications, the product member bracket, side mounting bracket, and mending plate are necessary. (SEE FIG 3B)

Please refer to table A for the proper hole alignment. If the table does not apply to the cabinet in use, the outer slots will provide a fully adjustable option to fit virtually any opening.

Using the M5 hardware provided, attach the mending plate to the side mounting brackets using hole locations "B". The mending plate should go underneath the side-mounting bracket with the numbers facing the floor and favoring the inside of the cabinet. (SEE FIG 3B)

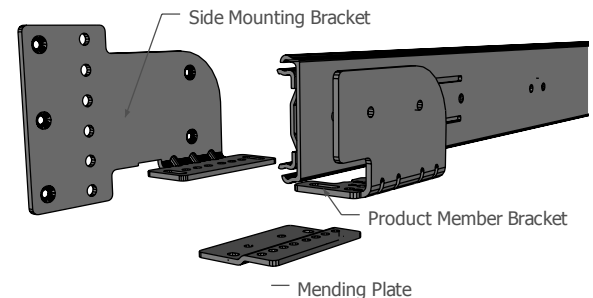
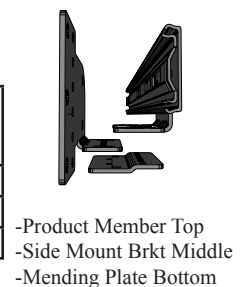

FIGURE 3B

TABLE A	SIDE MOUNTING BRACKET HOLE LOCATION	PRODUCT MEMBER HOLE LOCATION	RIGHT MENDING PLATE HOLE LOCATION	LEFT MENDING PLATE HOLE LOCATION
Frameless with .75" Wall	B	A	2 & 5	4 & 7
Frameless with .708" (18 mm) Wall	B	D	1 & 8	1 & 8
Frameless with .625" Wall	B	B	3 & 6	3 & 6



Step 4B

Set the entire chassis in the cabinet. The rear of the slides should insert into the rear strap assembly. This is a press fit and there will be resistance. The front product member bracket should sit on top of the mending plate installed in step 3B.

Step 5B

Using the remaining M5 hardware, assemble the product member bracket to the mending plate and side-mounting bracket according to TABLE 1. **PROCEED TO STEP 8**

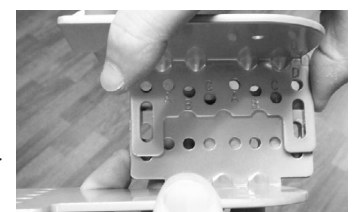

.75" Wall Example

Inset Door Application Installation Note: Requires 1/2" minimum wall thickness

Step 1C

Locate the bottom of the side mounting bracket 15-3/4" (for 50 qt. frames) or 10-11/16" (for 35 qt. frames) from the floor. The brackets also need to be flush with the front of the cabinet wall. Use the #6 X 5/8" screws provided to attach the bracket to the wall. You may also use additional #6 X 5/8" screws at the rear of the bracket for added stability.

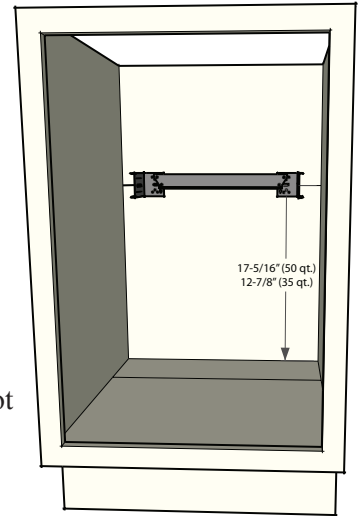

FIGURE 2C

STEP 2C

Position the rear strap assembly centered on the back wall and elevated so that the center slot of each rear socket is positioned at 17-15/16" (for 50 qt. frames) or 12-7/8" (for 35 qt. frames) above the cabinet floor. (SEE FIGURE 2C)

Fasten the rear strap assembly to the rear cabinet wall using the (4) #8 x 5/8" pan head screws provided. Make sure to center the strap assembly left to right according to the opening of the cabinet. It is best to start with 2 screws in the center slots in case adjustments are necessary.

Note: If rear of cabinet is thinner than 1/2", a furring strip should be used between the back wall and the mounting strap to ensure the rear mounting strap is properly attached. Keep in mind the minimum depth required is 21-3/4" and is measured from the back of the door.

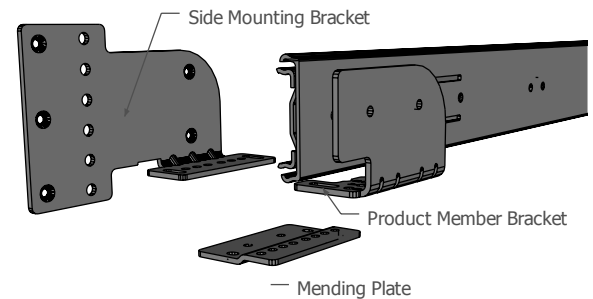
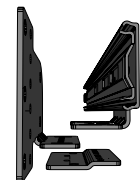

FIGURE 3C

Step 3C

For inset door applications, the product member bracket, side mounting bracket, and mending plate are necessary. (SEE FIG 3C)

Using the M5 hardware provided, attach the mending plate to the side mounting brackets using hole locations "B". The mending plate should go underneath the side-mounting bracket with the numbers facing the floor and favoring the inside of the cabinet. (SEE FIGURE 3C)



-Product Member Top
-Side Mount Brkt Middle
-Mending Plate Bottom

Step 4C

Set the entire chassis in the cabinet. The rear of the slides should insert into the rear strap assembly. This is a press fit and there will be resistance. The front product member bracket should sit on top of the mending plate installed in step 3C.

Because there are so many variations of cabinet construction it is difficult to state a specific hole pattern that will work best for your application. Center the chassis in the cabinet and confirm if there are any of the labeled holes that can be used to mate the brackets together. If not, the outer slots should provide enough width options to accommodate other sizes.

Using the remaining M5 hardware, assemble the product member bracket to the mending plate and side-mounting bracket. **PROCEED TO STEP 8**

Step 6

Re-engage the unit into each of the cabinet members being sure that the slides are aligned properly. Once engaged fully close and open the unit a few times to ensure proper slide operation.

Step 7

Re-install the gas spring being sure that the gas reservoir is attached to the top stud as shown in Figure 7A. Make sure to install both of the retainer clips into each of the stud caps.



FIGURE 7A

Step 8

Attach the telescopic foot to the lower stud mount using the #8-32 X 1/2" machine screws and flat washers provided (do not fully tighten). The stud mount is threaded so there is no need to use a nut and the foot itself is slotted. Once you are sure the foot is in full contact with the floor of the cabinet, tighten the machine screws. Now that the foot is the correct length attach it to the floor of the cabinet using (2) #8 x 5/8 deep thread screws provided. Make sure the foot and stud mount are perpendicular to the floor of the cabinet and do not lean left or right (this will cause interference with the gas spring that operates the waste container). (SEE FIGURE 8A)

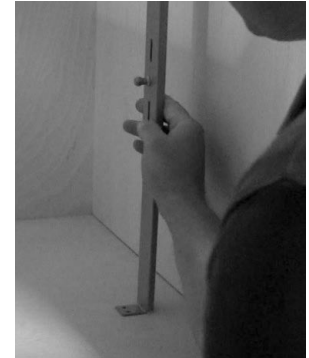

FIGURE 8A

Step 9

Attach door to unit. (SEE ENCLOSED DOOR MOUNTING INSTRUCTION SHEET)

Step 10 Test Function

Once the door has been properly attached test the function of the unit. During the first 5-10 cycles extend the frame to the fully open and fully closed positions assisting the entire length of travel. At this point the unit should open/close itself for the last 6-8" of travel.

NOTE: If the unit is not opening/closing fully or not operating smoothly check the following:

- Make sure that the installation of the front and rear brackets allows for the slides to be "square" without binding by measuring corner to corner on the slides with the unit in the open position .
- Check that the slides are both level front to back and that they are also level from one slide to the next (laying a level across both slides when waste container is in the open position).
- Check that the bottom foot is vertical front to back and left to right.



2409 Plantside Drive • Jeffersontown, KY 40299

800-626-1126

<http://www.rev-a-shelf.com>